

MODEL: SWK-610

Wheelbarrow

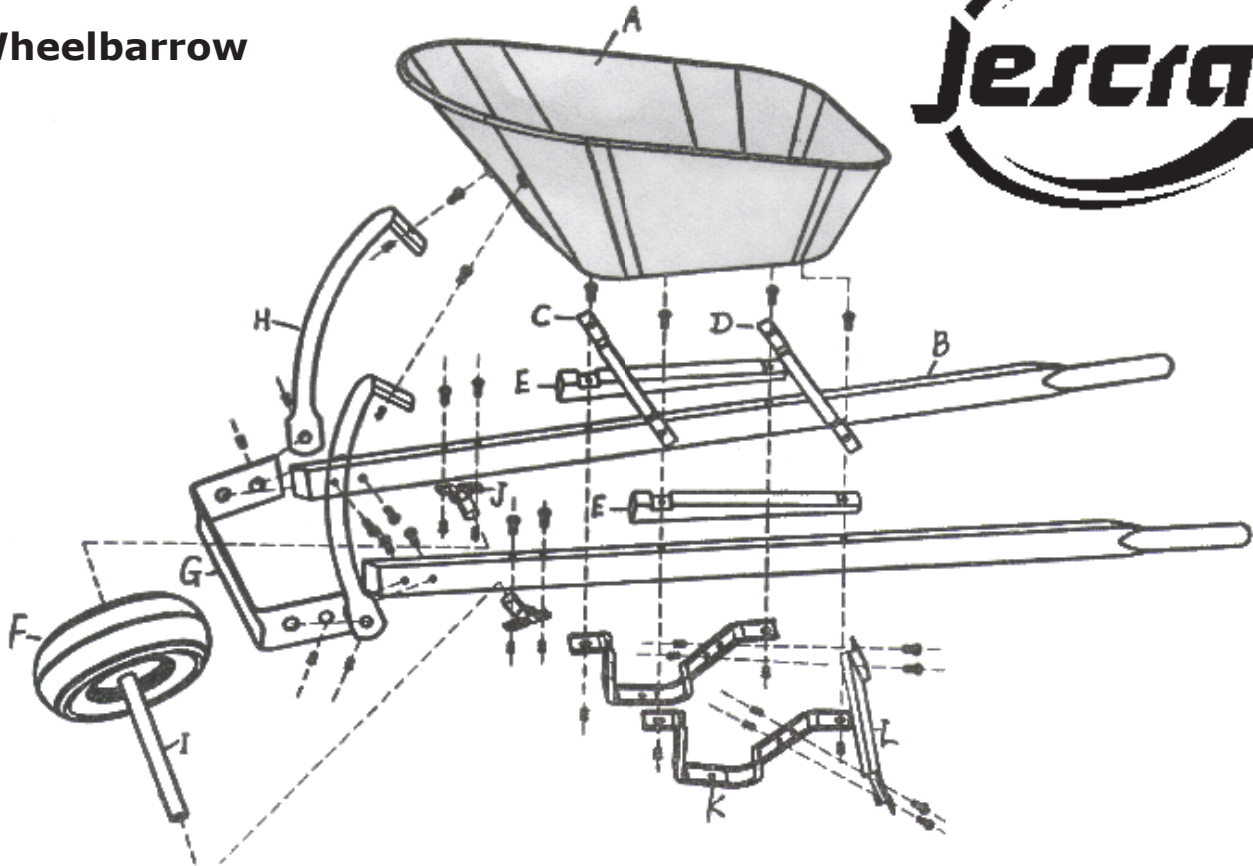

NO.	DESCRIPTION	QTY
A	WHEELBARROW TRAY	1 PC
B	STEEL HANDLE	2 PCS
C	SHORT STAY	1 PC
D	LONG STAY	1 PC
E	WOOD WEDGE	2 PCS
F	WHEEL	1 PC
G	NOSE GUARD	1 PC
H	TRAY BRACE	2 PCS
I	AXLE - 9 3/4" LONG	1 PC
J	AXLE BRACKET	2 PCS
K	LEG	2 PCS
L	LEG BRACE	1 PC
M	FASTENER BAG	1 SET

Assembly Instructions on Reverse Side

For assistance or missing parts contact Jescraft Customer Service at 1-800-524-1142

MODEL: SWK-610



Wheelbarrow Assembly Instructions

- 1) Before you begin, make sure all parts shown are included with your product. Parts may appear slightly different than illustrated. 13mm combination or socket wrench is required for installation.
- 2) DO NOT fully tighten nuts until entire wheelbarrow is assembled.
- 3) Place Tray (A) upside down on floor or low table. Insert two 5-1/2 inch long carriage bolts in center slots, facing the front of wheelbarrow tray (pointed end). Insert two 3-1/2 inch long carriage bolts in rear slots.
- 4) Place Long Stay (D) and Short Stay (C) over carriage bolts with the indent meeting Tray.
- 5) Slip Wood Wedges (E) over assembled carriage bolts, larger end to front (pointed end) of Tray.
- 6) Place Steel Handles (B) over Wood Wedges. The Steel Handle hole closest to grips is inserted over rear carriage bolt.
- 7) Attach Legs (K) over Steel Handle. Two unused vertical holes in each Leg face to rear of wheelbarrow. Attach serrated flange nut but DO NOT tighten.
- 8) Install Nose Guard (G) using four 1-3/4 inch long hex head cap screws. Serrated flange nuts should face to outside.
- 9) Loosely assemble two 3/4 inch long carriage bolts thru bent flange on Tray Braces (H) with carriage bolt heads facing to outside of tray brace. Slip head of carriage bolt into slot at nose of Tray and the other end over the front bolt on Nose Guard. Align and tighten 3/4 inch carriage bolt at Tray.
- 10) Attach Leg Brace (L) using four 3/4 inch long hex head cap screws. Jescraft Logo should orient to rear of wheelbarrow.
- 11) Attach one Axle Brackets (J) to frame using 3 inch long hex head cap screws. Slide Wheel (F) onto Axle (I) and insert Axle into Axle Bracket (J) previously attached to frame. With Axle now in place slip remaining Axle Bracket (J) onto Axle and attaché to frame with remaining 3 inch long hex head cap screws. Rotate wheel, adjust for free spinning. Tighten all serrated nuts securely.

FASTENER BAG CONTENTS

18 -	M6 Serrated Flange Nut	4 -	M6 x 45mm Hex Head Cap Screw (1 3/4")
2 -	M6 x 90mm Carriage Bolt (3 1/2")	4 -	M6 x 75mm Hex Head Cap Screw (3")
2 -	M6 x 140mm Carriage Bolt (5 1/2")	2 -	M6 x 20mm Carriage Bolt (3/4")
4 -	M6 x 20mm Hex Head Cap Screw (3/4")		